

In Record Time, Inc.

Index of Pre-Production Specifications

Compact Discs	Disc Imprint	2
	Folding Specs	3
	Book Specs	4
	Printed Area	5
	Single Insert	6
	Tray Card	7
	5" Jacket	8
	CDV Card	9
Cassettes	Imprint	10
	J-Cards	11
	O-Cards	12
	Video VHS Box	13
	Vinyl Labels	14

301 West 53rd Street, Suite #17A, New York, NY 10019

tele: 212.262.4414 fax: 212.262.4512

e-mail InRecTime@aol.com

www.inrecordtime.com

Adam Cott - President

Cd - Folding Specs

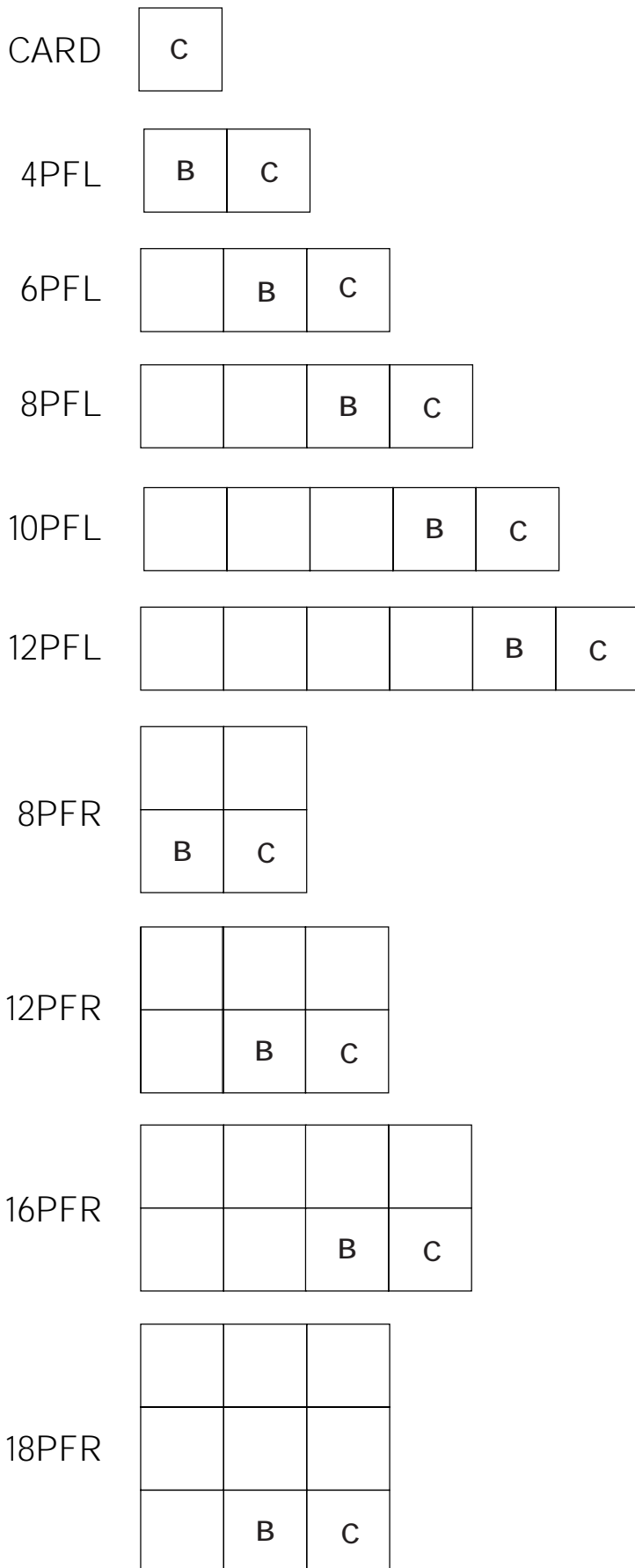

Legend:

- L.....Long
- F.....Folder
- xP.....Amount of Pages
- R.....Rectangle
- C.....Cover
- B.....Back

Note: Any changes to folding method or position of cover and back must be explained with a sample or dummy provide by you with your order.

For booklet type inserts, the sample must have a staple in the top-left hand corner to simulate the customers finished booklet.

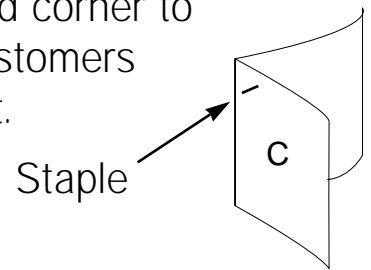

Looking at the cover, all folders will open right to left with the spine on the left hand side.

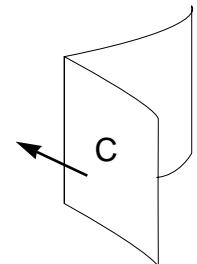

Cd - Booklet Specs

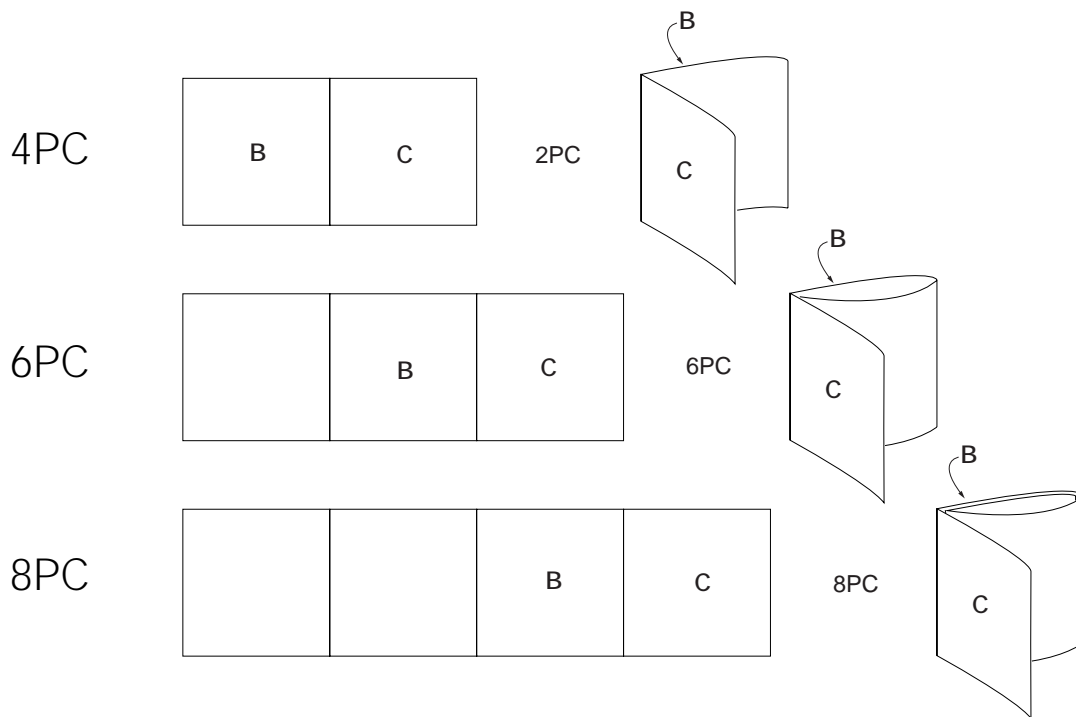

Note: Looking at the booklet cover, all booklets will open right to left with spine on the left hand side.

Legend:

L.....Long

F.....Folder

xP.....Amount of Pages

R.....Rectangle

C.....Cover

B.....Back

I.S. CD Inside Pages

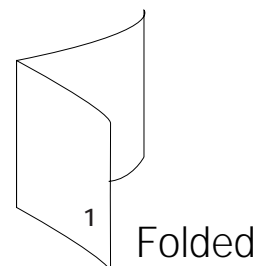
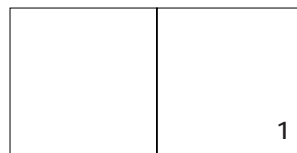

Note: All inside pages are multiples of 4 panels.

CD - 4 PFL Folder + PC Cover + IP

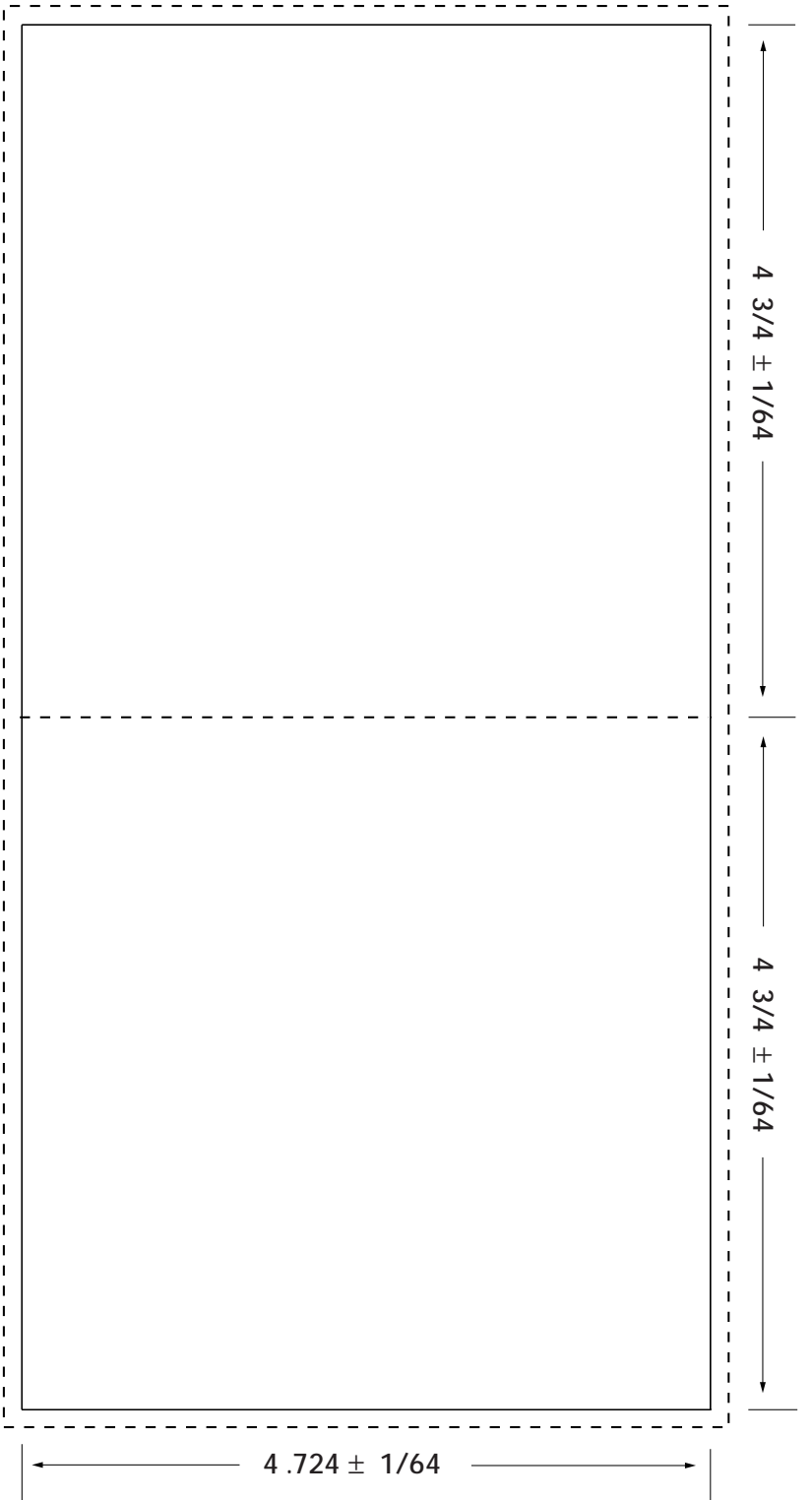

Client		PO #	
Ref.	4 PFL Folder + PC Cover + IP		
Size		O.B.	4.724 x 9.5
PGM #	29151 B	Date	
Board Thickness		Scale	

Merchandising Manufacturing Creative Services
 tele: 212.262.4414 Adam Cott - President fax: 212.262.4512

CD - 5" Jacket

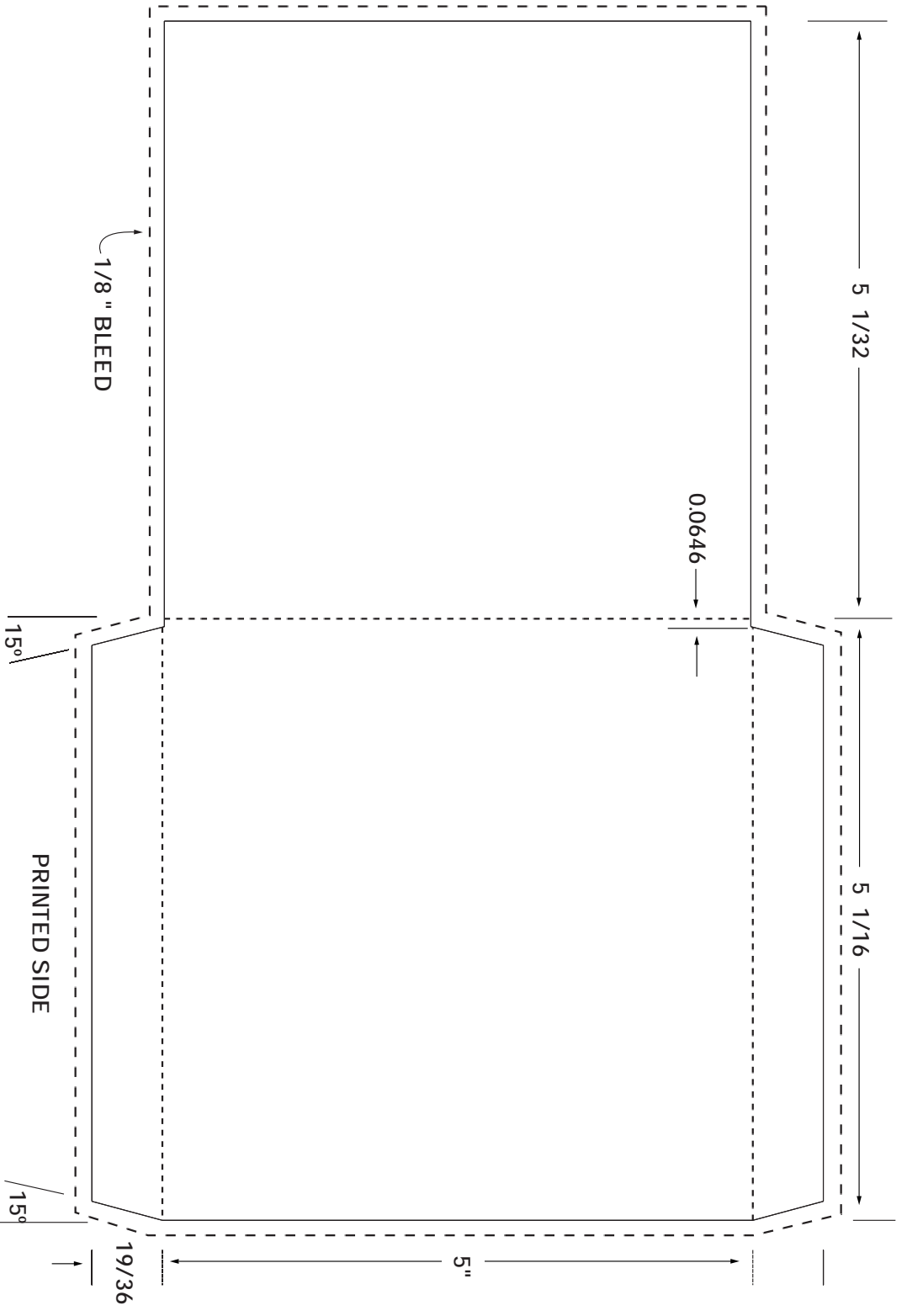
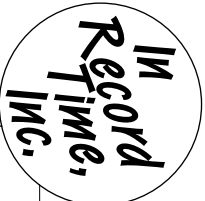

Client		PO #	
Ref.	5" Jacket	O.B.	6.1563 X 10.0938
Size		Date	
PGM #	34337 A	Scale	
Board Thickness	0.018		

Merchandising Manufacturing Creative Services
 tele: 212.262.4414 Adam Cott - President fax: 212.262.4512

CD - CDV Card

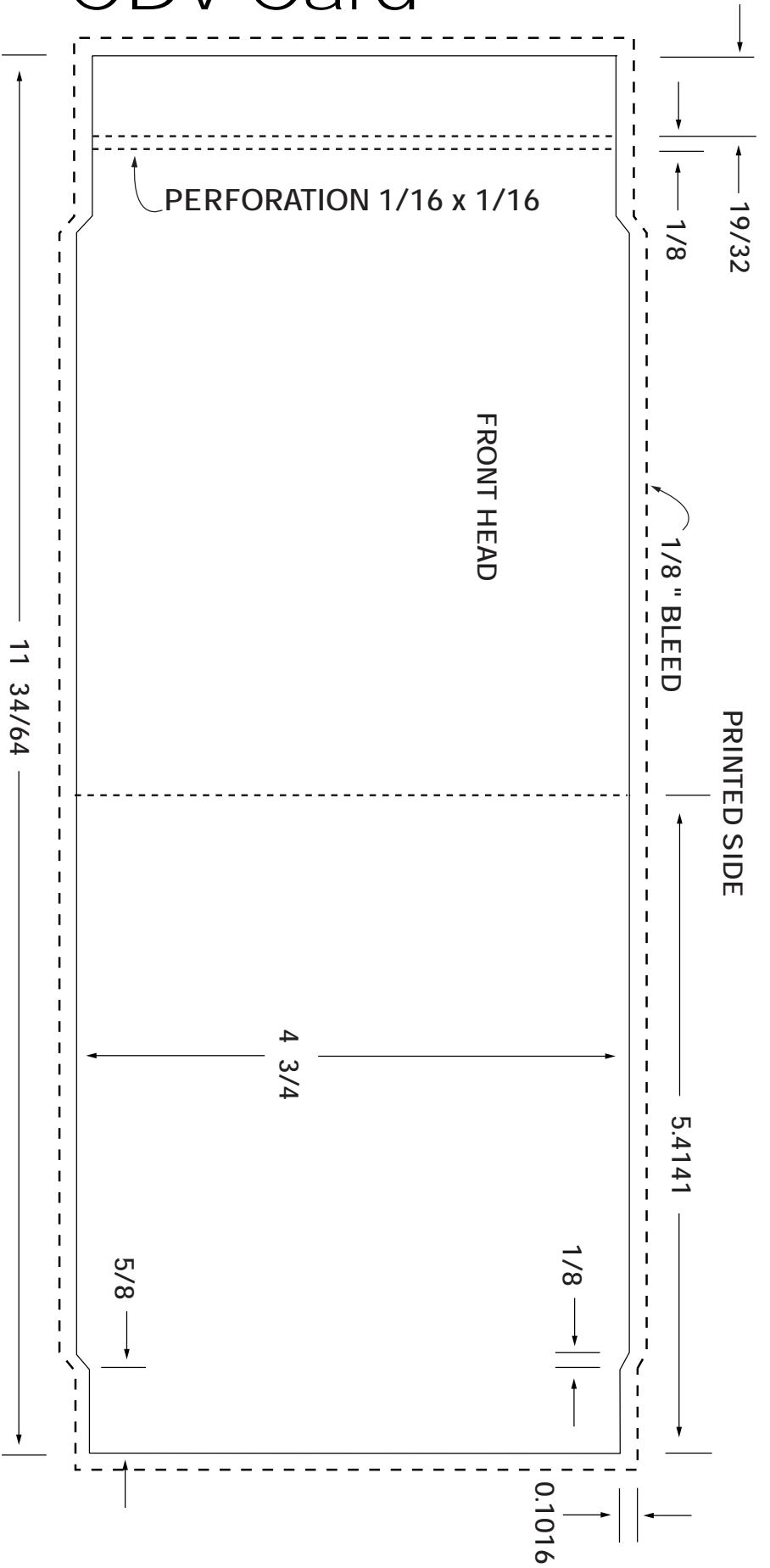

Client		PO #	
Ref.	CDV Card	O.B.	4.75 x 11.5469
Size		Date	
PGM #	18383 A	Scale	
Board Thickness			

Merchandising Manufacturing Creative Services
 tele: 212.262.4414 Adam Cott - President fax: 212.262.4512

Cassette - J-Card

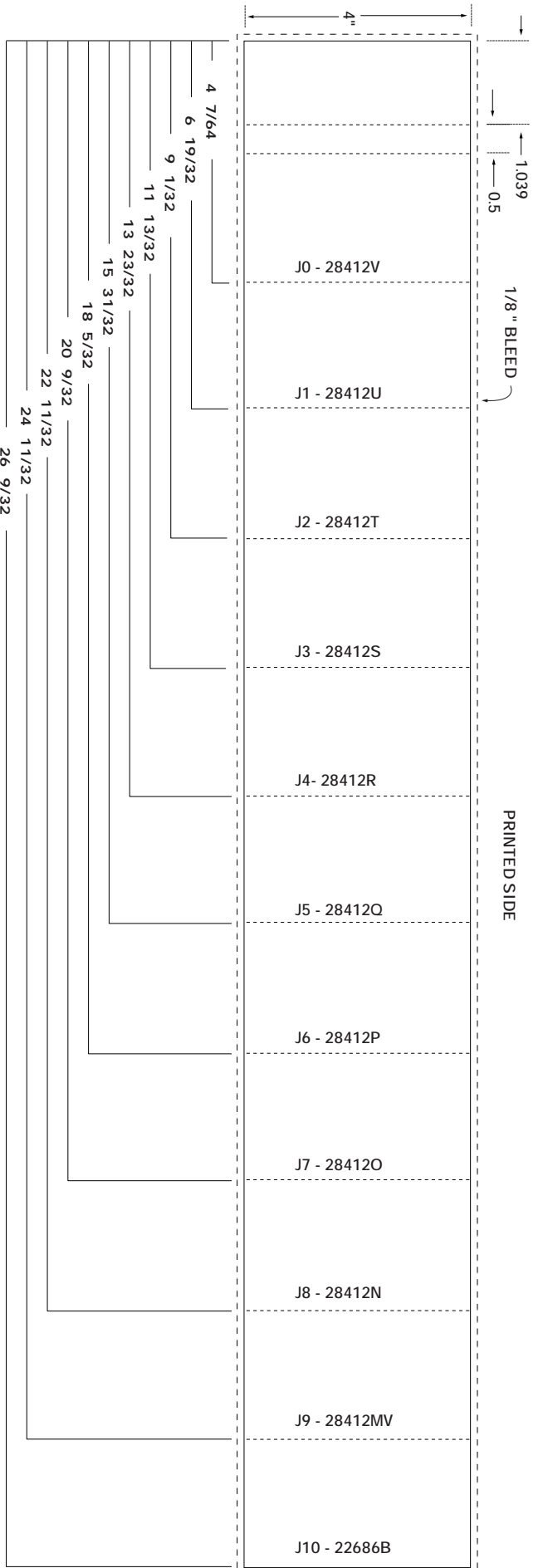

Client		PO #	
Ref.	J-Cards (J10 J9 J8 J7 J6 J5 J4 J3 J2 J1 J0)		
PGM #	22686B 28412M 28412N 28412O 28412P 28412Q		
PGM #	28412R 28412S 28412T 28412U 28412V	Date	
Board Thickness		Scale	

Merchandising Manufacturing Creative Services
 tele: 212.262.4414 Adam Cott - President fax: 212.262.4512

Vinyl Labels 12" & 7"

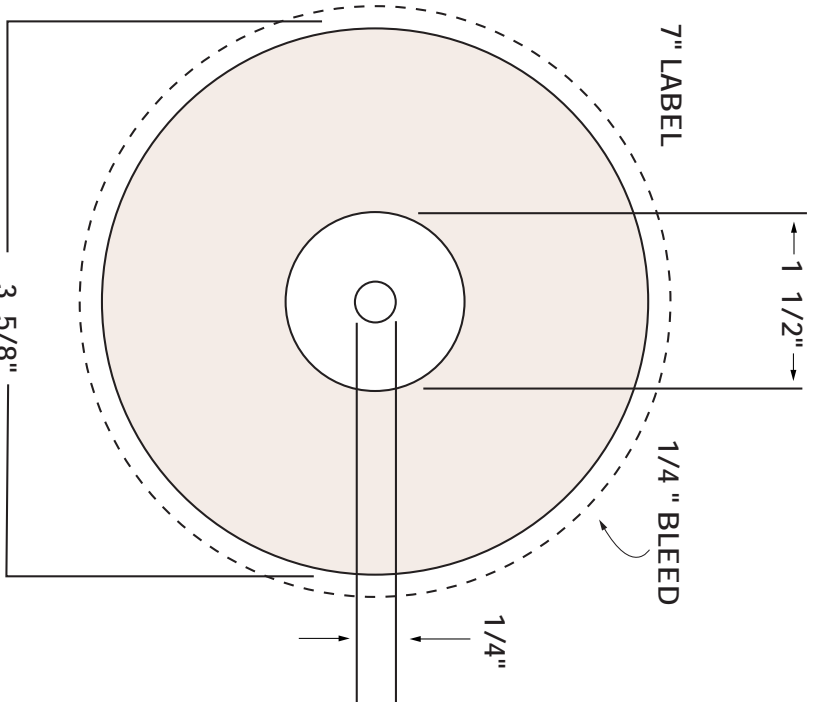
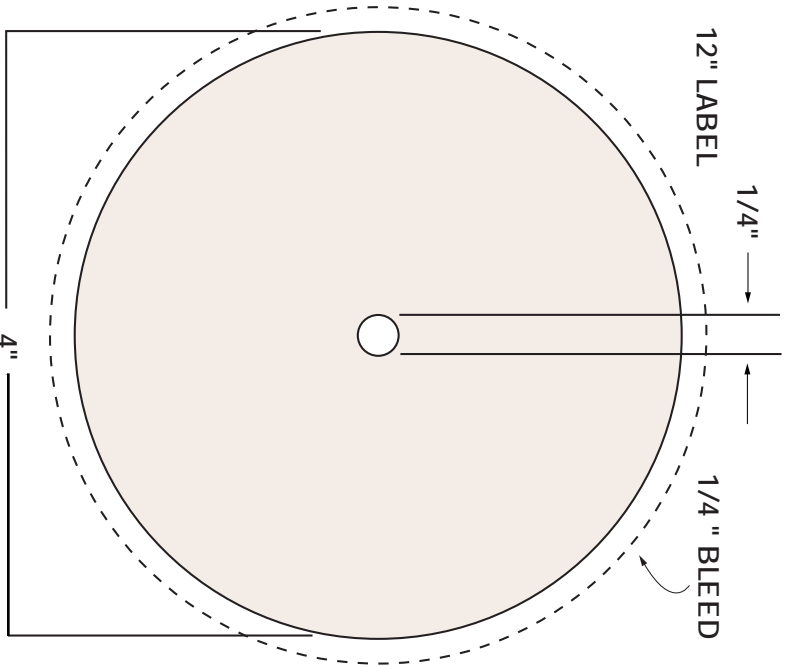

Please provide film negatives 133 LPI. Emulsion down, right reading.
All background images have to bleed about 1/4".

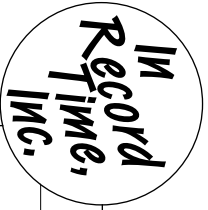

Client		PO #	
Ref.	Vinyl Labels - 12" & 7"	O.B.	
Size		Date	
PGM #		Scale	
Board Thickness			

Merchandising Manufacturing Creative Services
 tele: 212.262.4414 Adam Cott - President fax: 212.262.4512